

## RF Wireless Remote Control DC Linear Actuator Controller / Transmitter & Receiver

This is the DC linear actuator controller. The DC linear actuator controller can remote control one DC linear actuator (DC6V/9V/12V/24V) extending or retracting movement. You can connect two restrictive switches to receiver and use them to stop linear actuator movement.

### Package Include:

1 x Receiver: S1PF3-DC12 / S1PF3-DC06 / S1PF3-DC09 / S1PF3-DC24  
2 x Transmitter: CWC-3  
1 x Linear Actuator (0041534)  
2 x Fixing Brackets  
1 x User manual

### Features:

Wireless control, easy to install

Waterproof case with waterproof connectors. The receiver can be installed outdoors.

With high power of 30A

Control DC motors of rolling blinds / doors, projection screens, awnings, pumps, winches, conveyors or other appliances and mechanicals with voltage DC 6V/9V/12V/24V.

You can rotate the motor in positive or reversal direction with the transmitter (remote control) from any place within a reliable distance; the wireless signal can pass through walls, floors and doors.

Reliable control: The transmitter (Encoding) and the receiver (Decoding) use an 8-bit code.

One/several transmitters can control one/several receivers simultaneously.

If you use two or more receivers in the same place, you can set them with different codes.

Transmitting Frequency: 433MHz

### Receiver:

Model No.: S1PF3-DC12 / S1PF3-DC06 / S1PF3-DC09 / S1PF3-DC24

Coding Type: Fixed code or learning code

Coding Setting: By learning

Power Supply (Operating Voltage): DC6V (S1PF3-DC06), DC9V±1V (S1PF3-DC09), DC12V±1V (S1PF3-DC12), DC24V±1V (S1PF3-DC24)

Output: DC6V (S1PF3-DC06), DC9V (S1PF3-DC09), DC12V (S1PF3-DC12), DC24V (S1PF3-DC24)

Case Size: 100mm x 67mm x 39mm

Quiescent Current: 5mA

Rated Current: 15A

The Maximum Instantaneous Current of Starting Motor: 30A

### Transmitter:

Model No.: 0021102 (CWC-3)

Channel: 3 CH

Waterproof

Remote Control Distance: 50m / 300ft (theoretically)

Encode: Fixed code by soldering

Unit Size: 58mm x 30mm x 12mm

Power Supply: 1 x 23A -12V battery (included, can be used for 12 months)

### Usage:

#### Power supply:

Connect power supply DC 6V/9V/12V/24V to terminal "INPUT"; connect linear actuator to terminal "OUTPUT". You can exchange the output wires of linear actuator to change the extending or retracting movement of linear actuator.

#### Setting control mode Latched: Connect JP1

##### Function of transmitter:

Press button ▲ on remote: terminal "Output" outputs DC power, motor rotates in positive direction.

Press button ▼ on remote: terminal "Output" outputs DC power, motor rotates in reversal direction.

Press button ● on remote: motor stops.

##### Function of manual buttons in receiver:

Press button K3 in receiver: terminal "Output" outputs DC power, motor rotates in positive direction.

Press button K1 in receiver: terminal "Output" outputs DC power, motor rotates in reversal direction.

Press button K2 in receiver: motor stops.

#### Setting control mode Momentary: Connect JP2

##### Function of transmitter:

Press and hold button ▲ on remote: terminal "Output" outputs DC power, motor rotates in positive direction. Release button: motor stops.

Press and hold button ▼ on remote: terminal "Output" outputs DC power, motor rotates in reversal direction. Release button: motor stops.

##### Function of manual buttons in receiver:

Press and hold button K3 in receiver: terminal "Output" outputs DC power, motor rotates in positive direction. Release button: motor stops.

Press and hold button K1 in receiver: terminal "Output" outputs DC power, motor rotates in reversal direction. Release button: motor stops.

#### Setting control mode Momentary: Connect Jumper S2

##### Function of manual buttons in receiver:

Press and hold button K3 in receiver: terminal "Output" output DC power, motor rotates in positive direction. Release button: motor stops.  
 Press and hold button K1 in receiver: terminal "Output" output DC power, motor rotates in reversal direction. Release button: motor stops.

**Restrictive function:**

You can connect two restrictive switches to terminals "X1" and "X2", if the restrictive switch X1 or X2 is connected, the linear actuator will extending or retracting movement; if the restrictive switch X1 or X2 is disconnected, the linear actuator will stop automatically. That means when the restrictive switch "X1" is connected, the linear actuator will extending movement; when the restrictive switch "X1" is disconnected, linear actuator will stop automatically. When the restrictive switch "X2" is connected, the linear actuator will retracting movement; when the restrictive switch "X2" is disconnected, linear actuator will stop automatically.

**Learning the button of transmitter:**

- 1) Press and hold "K3" button of receiver; when signal LED on the receiver begin to shine, release "K3" button. Before signal LED shines 5 seconds, press ▲ button of transmitter, if the signal LED off, that means learning is successful.
- 2) Press and hold "K2" button of receiver; when signal LED on the receiver begin to shine, release "K2" button. Before signal LED shines 5 seconds, press ● button of transmitter, if the signal LED off, that means learning is successful.
- 3) Press and hold "K1" button of receiver; when signal LED on the receiver begin to shine, release "K1" button. Before signal LED shines 5 seconds, press ▼ button of transmitter, if the signal LED off, that means learning is successful.

**Delete the button of transmitter:**

We have learned transmitter to the receiver. If you don't want the receiver to work with transmitter, you can delete all codes of transmitter which are stored in the receiver. You can operate as following:

- Press and hold "K3" button of receiver; when signal LED on the receiver begin to shine, then flicker, finally off, that means deleting is successful.
- Press and hold "K2" button of receiver; when signal LED on the receiver begin to shine, then flicker, finally off, that means deleting is successful.
- Press and hold "K1" button of receiver; when signal LED on the receiver begin to shine, then flicker, finally off, that means deleting is successful.

**Note:** Before you change from linear actuator extending movement to retracting movement or from linear actuator retracting movement to extending movement, you should stop extending or retracting movement of linear actuator firstly, then remote control linear actuator.

**Application Circuit**

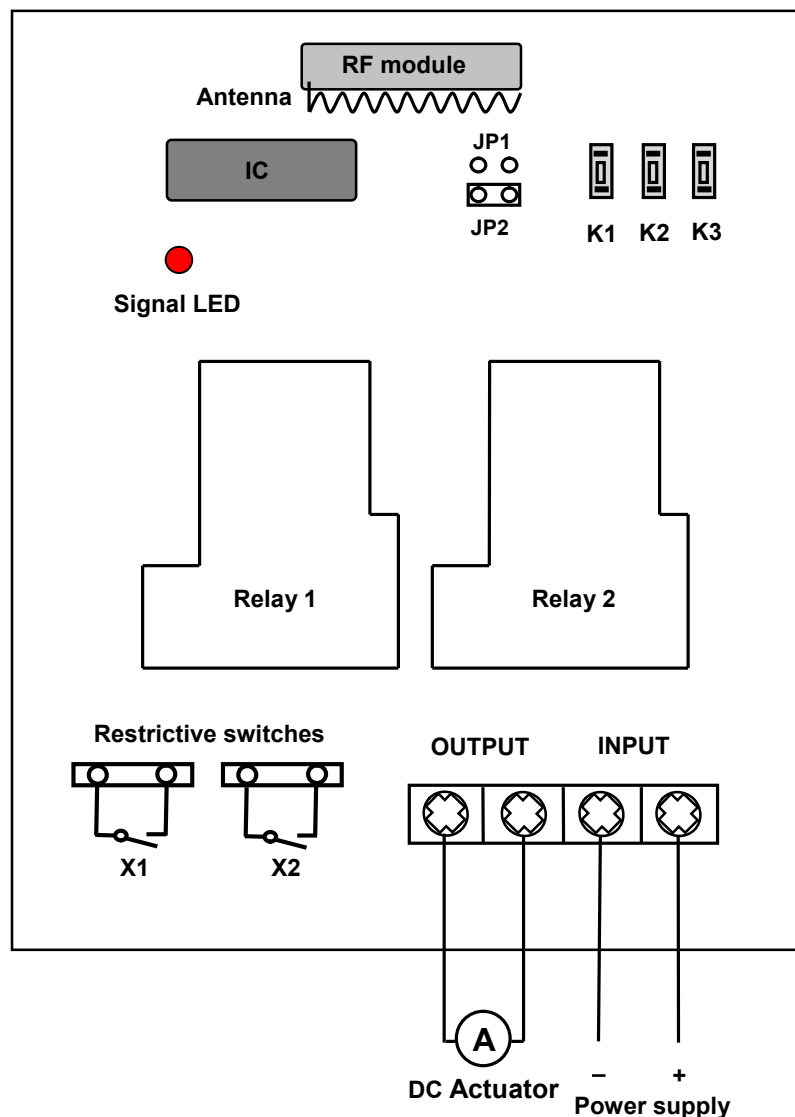

## 18" / 450mm Stroke Heavy Duty Linear Actuator 400 Pound / 200KG Max Lift 12 Volt or 24 Volt DC

### Application:

Mainly used for cars, lifting platforms, massage couches, electric beds, medical chairs, electric devices, micro-devices and so on. It can push, pull, lift and descend other devices.

### Feature:

- High quality
- Generate linear motion
- DC motor activated
- Heavy duty design
- Low power consumption
- Low noise design
- Wiring included, pre-installed
- Identical extending or retracting
- Built-in clutch prevents over-extending and over-compressing

### Specifications:

Working voltage: DC 12V or DC 24V

Extension: 18" / 450mm

Compressed length from center of two mounting holes (shaft retracts completely): 25" / 625mm

Extended Length from center of two mounting holes (shaft extends completely): 43" / 1075mm

Speed: 5mm±2mm/second, or 10mm±3mm/second, or 30mm±5mm/second

Max Load capacity: 400 Pound / 200 Kg at 5mm/second, or 200 Pound / 100 Kg at 10mm/second, or 100 Pound / 50 Kg at 30mm/second

The linear actuator can get the maximum load capacity when it operates in the vertical direction.

Working current: 6A (you should choose a 10A power adapter to power this actuator, like our model 0010130)

Shaft diameter: 24mm

Mounting holes diameter: 10mm

Environment temperature: -26°C to 85°C

Noise level: lower than 42dB

IP rating: IP54

Weight: 3400g

### Operation:

Extending or retracting movement

Moving direction can be changed by switching polarity.

