

5000 Meters RF Wireless Receiver (Model 0020054 S8UW-DC-ANT3)

Package Include:

1 x Receiver: S8UW-DC-ANT3
1 x User manual

Application:

This receiver is an electric device with 8 dry relay outputs, it and the transmitter form a receiver transmitter system. This system may be used in all types of industry automation, agriculture, home, factory, house, farm, vehicle, ship, offshore operations, aerial vehicle, etc. It can remote control equipment on land, water and air, such as remote control of lights, sirens, locks, motors, fans, winches, blinds, linear actuators, doors, windows, electric solenoid valves, security alarm, and business signs. The applications are endless.

Feature:

Wireless control, easy to install.

Super long working range: With the transmitter forming a complete set, the maximum working distance may reach 5000 meters in an open area.

Wide operating voltage range: 9~28VDC

Relay Output: This receiver is dry relay output, it can be used to operate both DC and AC equipment. The output terminals are NO / NC (normally open / normally closed), serving as a switch.

With external antenna, the receiver has a farther working range.

The transmitter / remote can control the receiver from any place within a reliable working distance.

The wireless RF signal from the transmitter can pass through walls, floors, doors or windows, but it will lose some operating range.

The receiver has reverse power protection and over current protection built in.

The receiver only works with the selected transmitter which is matched to the receiver.

One or more transmitters / remotes can control one or several receivers simultaneously.

Two or more receivers may be used in the same area.

Feedback Function:

The receiver and the transmitter have a Two-way working mode, so the user can know the working status of the receiver by the transmitter.

Two-way working mode: When the receiver is successfully triggered by the signal from the transmitter, it will immediately transmit a feedback signal to the transmitter, then the transmitter will send out a buzzing sound to inform you that the receiver has been successfully triggered.

Receiver Parameters:

Model No.: S8UW-DC

Operating Voltage: 9~28VDC

Working Frequency: 433.92 MHz

Quiescent Current: $\leq 10\text{mA}$

Channel: 8 CH

Output Type: Dry Relays Output (Normally Open and Normally Closed)

Maximum Load Voltage of Relay: 240VAC or 28VDC

Maximum Load Current of Relay: 10A / each channel

Wire Range of Terminals: 22-12 AWG

3 Selectable Modes: Self-locking, Momentary, Interlocking

Operating Temperature: $-20^{\circ}\text{C} \sim +70^{\circ}\text{C}$

PCB size: 122 x 87 x 18 mm (4.8x 3.4 x 0.7 inches)

Case size: 145 x 90 x 40 mm (5.7 x 3.5 x 1.6 inches)

Matching Transmitters:

This receiver only works with 5000m transmitters, such as model CC-8 (5000 Meter / 15000 feet range).

Working Range:

With the transmitter (such as CC-8) forming a complete set, the maximum working distance may reach 5000 meters in an open area.

The maximum working distance is based on theoretical data which would be without barriers and without any RF interference. In practice, it will be hindered by trees, walls or other construction, and will be interfered with by other wireless signals. Therefore, the actual working distance may not reach this maximum distance.

Usage:

The receiver can be used to control both DC 0~28V and AC 110~240V equipments.

Notice: The receiver is dry relay output, not DC/AC power output. Initial state of relay output terminals: Terminals G and K are Normally Open; Terminals G and B are Normally Closed.

Wiring:

1) If you want to control a DC 12V lamp, do as following:

1.1 Connect the positive pole of DC power supply to terminal VCC, and connect the negative pole of DC power supply to terminal GND.

1.2 Connect terminal K to the positive pole of DC power supply, connect terminal G to the positive pole of DC lamp, and connect the negative pole of DC lamp to the negative pole of DC power supply.

2) If you want to control an AC 220V lamp, do as following:

2.1 Connect the positive pole of DC power supply to terminal VCC, and connect the negative pole of DC power supply to terminal GND.

2.2 Connect terminal K to the live wire of AC power supply, connect terminal G to one side of AC lamp, and connect another side of AC lamp to the

neutral wire of AC power supply.

Setting different control modes:

The receiver will be set in Self-locking mode before shipping, if you require another mode, implement the following steps.

Notice: You need to restart the power of the receiver after changing the control mode.

1) Setting Self-locking mode: Connect two terminals M and T by the pin.

The operation of Self-locking mode with the transmitter CC-8: Press any button on the transmitter, the corresponding relay in the receiver is activated;

Press the button again, the corresponding relay is deactivated. Such as the following,

Press the button 1 on the transmitter: The relay 1 in the receiver is activated, and the connected lamp 1 is turned on.

Press the button 1 again: The relay 1 is deactivated, and the connected lamp 1 is turned off.

Press the button 2 on the transmitter: The relay 2 in the receiver is activated, and the connected lamp 2 is turned on.

Press the button 2 again: The relay 2 is deactivated, and the connected lamp 2 is turned off.

.....

Press the button 8 on the transmitter: The relay 8 in the receiver is activated, and the connected lamp 8 is turned on.

Press the button 8 again: The relay 8 is deactivated, and the connected lamp 8 is turned off.

2) Setting Momentary mode: Do not connect any terminals.

The operation of Momentary mode with the transmitter CC-8: Press and hold any button on the transmitter, the corresponding relay in the receiver is activated; Release the button, the corresponding relay is deactivated. Such as the following,

Press and hold the button 1 on the transmitter: The relay 1 in the receiver is activated, and the connected lamp 1 is turned on.

Release the button 1: The relay 1 is deactivated, and the connected lamp 1 is turned off.

Press and hold the button 2 on the transmitter: The relay 2 in the receiver is activated, and the connected lamp 2 is turned on.

Release the button 2: The relay 2 is deactivated, and the connected lamp 2 is turned off.

.....

Press and hold the button 8 on the transmitter: The relay 8 in the receiver is activated, and the connected lamp 8 is turned on.

Release the button 8: The relay 8 is deactivated, and the connected lamp 8 is turned off.

3) Setting Interlocking mode: Connect two terminals M and L by the pin.

The operation of Interlocking mode with the transmitter CC-8: Press any button on the transmitter, the corresponding relay in the receiver is activated and other all relays are deactivated. Such as the following,

Press the button 1 on the transmitter: The relay 1 in the receiver is activated, and the connected lamp 1 is turned on. 7 other relays are deactivated, and 7 other connected lamps are turned off.

Press the button 2 on the transmitter: The relay 2 in the receiver is activated, and the connected lamp 2 is turned on. 7 other relays are deactivated, and 7 other connected lamps are turned off.

.....

Press the button 8 on the transmitter: The relay 8 in the receiver is activated, and the connected lamp 8 is turned on. 7 other relays are deactivated, and 7 other connected lamps are turned off.

How to set the feedback function:

You can turn on the third bit of the dip switch to activate the feedback function, or turn off the third bit to deactivate the feedback function.

Notice: Other two bits of the dip switch are useless, please keep them off.

How to pair the transmitter to the receiver:

Notice: We have paired the transmitter to the receiver before shipping.

1) Press the learning button in the receiver for 1~2 seconds, signal LED on the receiver turns on, this indicates that the receiver enters the learning status.

2) Press any one button on the transmitter, if signal LED flashes twice, this indicates that the pairing is successful.

3) The receiver can learn several transmitters with different codes.

How to delete all transmitters codes stored in the receiver:

We have paired the transmitter to the receiver, if you don't want the receiver to work with the transmitter, you can delete all transmitters codes stored in the receiver.

Operation: Press and hold the learning button in the receiver until signal LED flashes three times, then release the button, this indicates that all stored codes have been deleted successfully.

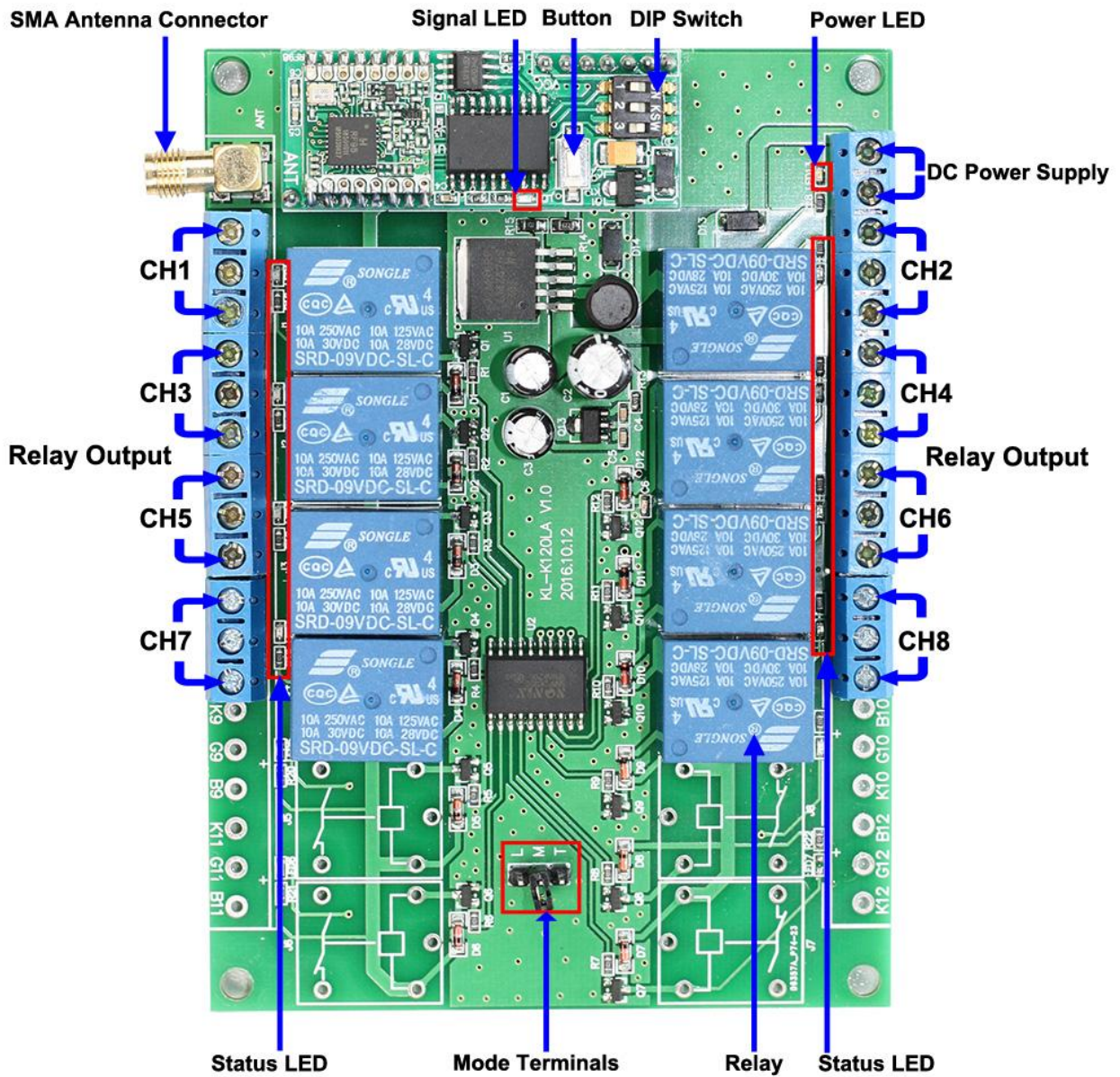

Control DC Equipments

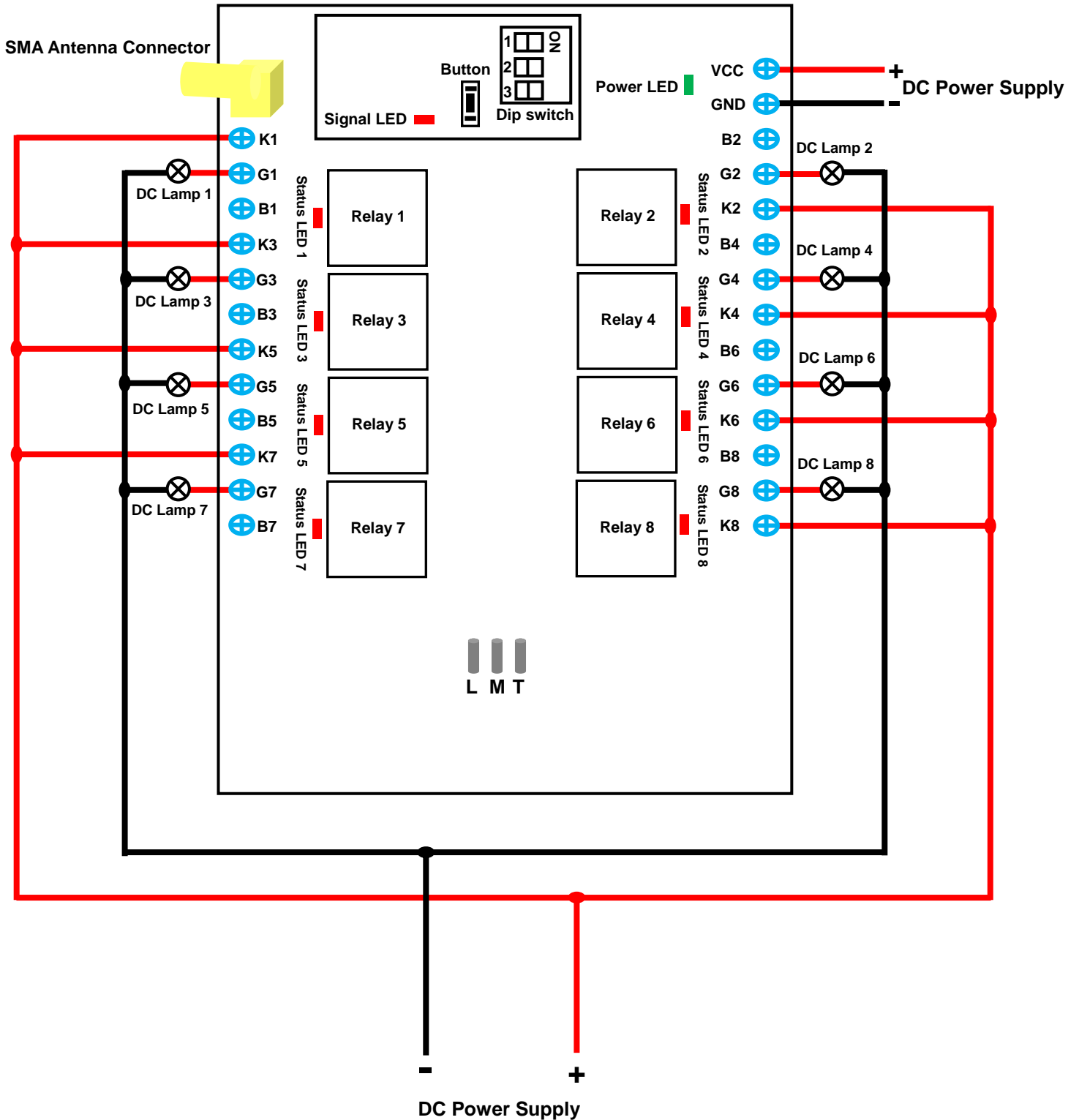

Control AC Equipments

