

## RF Wireless Remote Control Kit (Model 0020354)

### Package Include:

4 x Receiver: S1U-DC-ANT3 (1 Channel / Three Control Modes)  
1 x Transmitter: CB-4  
1 x User manual

### Feature:

Application: It can be used in industry automation, agriculture automation and home automation, such as factory, house, farm, pasture, vehicle, ship, offshore operation, aerial vehicle, field call, etc. It can remote control equipments on land, water and air, such as remote control lights, sirens, locks, motors, fans, winches, blinds, linear actuators, doors, windows, electric solenoid valves, security alarm, business signs and various devices.

Wireless control, easy to install..

Power Supply: Four working voltage versions, DC 6V, 9V, 12V, 24V.

Relay Output: This receiver is dry relay output, it can be used to operate both DC and AC equipments. The output terminals are NO / NC (normally open / normally closed), which serves as a switch. That means you should also connect a separate power supply to equipments.

Each channel can work at maximum current 10A, such as 120W/12V, 60W/6V, 90W/9V, 240W/24V, 1100W/110V, 2200W/220V.

With external telescopic antenna, the receiver have a farther working range.

You can control the equipments by using the receiver with transmitter (remote control) from any place within a reliable distance.

Wireless RF signal can pass through walls, floors, doors or windows.

With reverse power protection and over current protection.

Reliable control: The code has thousands of different combinations, and the receiver only works with the transmitter which use the same code.

One/several transmitters can control one/several receivers simultaneously.

You can use two or more units in the same place.

### Receiver Parameters:

Model No.: S1U-DC06 / S1U-DC09 / S1U-DC12 / S1U-DC24

Power Supply (Operating Voltage): DC6V (S1U-DC06), DC9V±1V (S1U-DC09), DC12V±1V (S1U-DC12), DC24V±2V (S1U-DC24)

Output: Relay output (Normally open and normally closed)

Working Voltage Range of Relay: AC110~240V or DC0~28V

Wire range for the terminals: 22-14 AWG

Working Frequency: 433.92MHz

Channel: 1 CH

Control Modes: Self-locking, Momentary, Interlocking

Static Current: ≤6mA

Maximum Working Current: 10A / each channel

PCB size: 67mm x 50mm x 18mm

Case size: 75mm x 54mm x 27mm

### Transmitter Parameters:

Model No.: CB-4

Channel: 4 CH

Remote Control Distance: 1000m / 3000ft (theoretically)

Encode: Fixed code by soldering

Unit size: 135mm x 42mm x 25mm

Power Supply: 1 x 6F22-9V battery (included, can be used for 12 months)

### Matching Transmitters:

The receiver can work with different transmitters, such as model C-4 (100M), CWB-4 (50M, waterproof), or CB-4 (1000M) etc.

### Working Range:

Super long range, with a transmitter (such as CB-4) to form a complete set, the maximum working distance can reach 2000M in an open ground.

The maximum working distance is a theoretical data, it shall be operated in an open ground, no barriers, no any interference. But in the practice, it will be hindered by trees, walls or other constructions, and will be interfered by other wireless signals. Therefore, the actual distance may not reach this maximum working distance.

### Usage (with the transmitter CB-4):

The receiver can be used to control both DC 0~28V and AC 110~240V equipments.

Notice: The receiver is relay output, not DC/AC power output. Initial state of relay output terminals: Terminals B and C are Normally Open; Terminals A and B are Normally Closed.

### Wiring:

If you want to control a DC 12V lamp, do as following:

- 1) Connect the positive pole of DC power supply to terminal "L / +" of INPUT, and connect the negative pole of DC power supply to terminal "N / -" of INPUT.
- 2) Connect terminal C to the positive pole of DC power supply, connect terminal B to the positive pole of DC lamp, and connect the negative pole of DC lamp to the negative pole of DC power supply.

If you want to control an AC 220V lamp, do as following:

- 1) Connect the positive pole of DC power supply to terminal "L / +" of INPUT, and connect the negative pole of DC power supply to terminal "N / -" of

INPUT.

2) Connect terminal C to the live wire of AC power supply, connect terminal B to one side of AC lamp, and connect another side of AC lamp to the neutral wire of AC power supply.

#### **Setting different control modes:**

Setting different control modes (We have set the receiver as Self-locking control mode before delivery. If you want to use other control modes, do as following operation):

Setting control mode Self-locking: Only connect Jumper-2.

Control mode Self-locking: Press -> On; Press again -> Off.

Press button A: Relay of the receiver 1 is activated (connect the terminals B and C, disconnect the terminals A and B), and the lamp 1 is turned on.

Press button A again: Relay of the receiver 1 is deactivated (disconnect the terminals B and C, connect the terminals A and B), and the lamp 1 is turned off.

Press button B: Relay of the receiver 2 is activated (connect the terminals B and C, disconnect the terminals A and B), and the lamp 2 is turned on.

Press button B again: Relay of the receiver 2 is deactivated (disconnect the terminals B and C, connect the terminals A and B), and the lamp 2 is turned off.

Press button C: Relay of the receiver 3 is activated (connect the terminals B and C, disconnect the terminals A and B), and the lamp 3 is turned on.

Press button C again: Relay of the receiver 3 is deactivated (disconnect the terminals B and C, connect the terminals A and B), and the lamp 3 is turned off.

Press button D: Relay of the receiver 4 is activated (connect the terminals B and C, disconnect the terminals A and B), and the lamp 4 is turned on.

Press button D again: Relay of the receiver 4 is deactivated (disconnect the terminals B and C, connect the terminals A and B), and the lamp 4 is turned off.

Setting control mode Momentary: Only connect Jumper-1.

Control mode Momentary: Press and hold -> On; Release -> Off.

Press and hold button A: Relay of the receiver 1 is activated (connect the terminals B and C, disconnect the terminals A and B), and the lamp 1 is turned on.

Release button A: Relay of the receiver 1 is deactivated (disconnect the terminals B and C, connect the terminals A and B), and the lamp 1 is turned off.

Press and hold button B: Relay of the receiver 2 is activated (connect the terminals B and C, disconnect the terminals A and B), and the lamp 2 is turned on.

Release button B: Relay of the receiver 2 is deactivated (disconnect the terminals B and C, connect the terminals A and B), and the lamp 2 is turned off.

Press and hold button C: Relay of the receiver 3 is activated (connect the terminals B and C, disconnect the terminals A and B), and the lamp 3 is turned on.

Release button C: Relay of the receiver 3 is deactivated (disconnect the terminals B and C, connect the terminals A and B), and the lamp 3 is turned off.

Press and hold button D: Relay of the receiver 4 is activated (connect the terminals B and C, disconnect the terminals A and B), and the lamp 4 is turned on.

Release button D: Relay of the receiver 4 is deactivated (disconnect the terminals B and C, connect the terminals A and B), and the lamp 4 is turned off.

Setting control mode Interlocking: Disconnect Jumper-1 and Jumper-2.

Press button A: Relay of the receiver 1 is activated (connect the terminals B and C, disconnect the terminals A and B), and the lamp 1 is turned on.

Relay of the receiver 2, 3, 4 are deactivated (disconnect the terminals B and C, connect the terminals A and B, other lamps are off).

Press button B: Relay of the receiver 2 is activated (connect the terminals B and C, disconnect the terminals A and B), and the lamp 2 is turned on.

Relay of the receiver 1, 3, 4 are deactivated (disconnect the terminals B and C, connect the terminals A and B, other lamps are off).

Press button C: Relay of the receiver 3 is activated (connect the terminals B and C, disconnect the terminals A and B), and the lamp 3 is turned on.

Relay of the receiver 1, 2, 4 are deactivated (disconnect the terminals B and C, connect the terminals A and B, other lamps are off).

Press button D: Relay of the receiver 4 is activated (connect the terminals B and C, disconnect the terminals A and B), and the lamp 4 is turned on.

Relay of the receiver 1, 2, 3 are deactivated (disconnect the terminals B and C, connect the terminals A and B, other lamps are off).

#### **How to pair the transmitter to the receiver:**

1) Press the learning button of receiver for 1- 2 seconds; signal LED on the receiver is on. The receiver enters into status of LEARNING.

2) Press any one button on transmitter. If signal LED flashes quickly 15 times and turns off, it means learning is successful.

3) When receiver is in the status of LEARNING, press again the learning button, signal LED turns off, learning process will be discontinued.

4) The receiver can learn several remote controls with different codes.

#### **Delete all transmitters:**

We have learned remote control to the receiver. If you don't want the receiver to work with the remote control, you can delete all codes of remote controls, which are stored in the receiver.

Operation: Press and hold the learning button of receiver until signal LED flashes slowly; release the button, LED keeps slow flash. That means all stored codes have been deleted successfully.

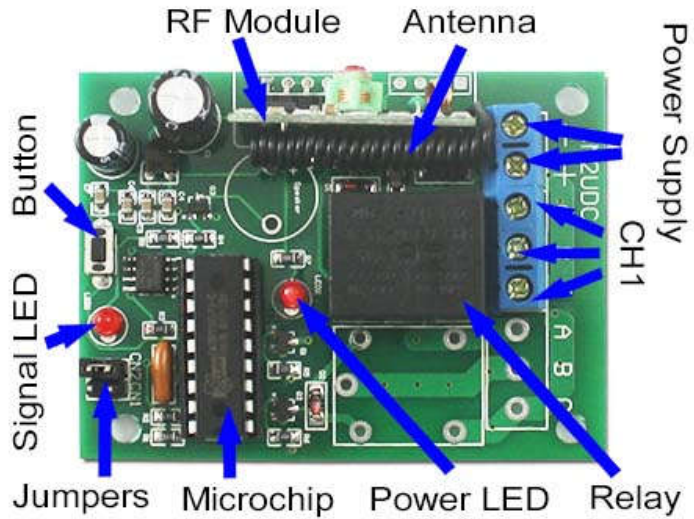

A,B=Normally Closed;B,C=Normally Open.

**Control DC Lamp**

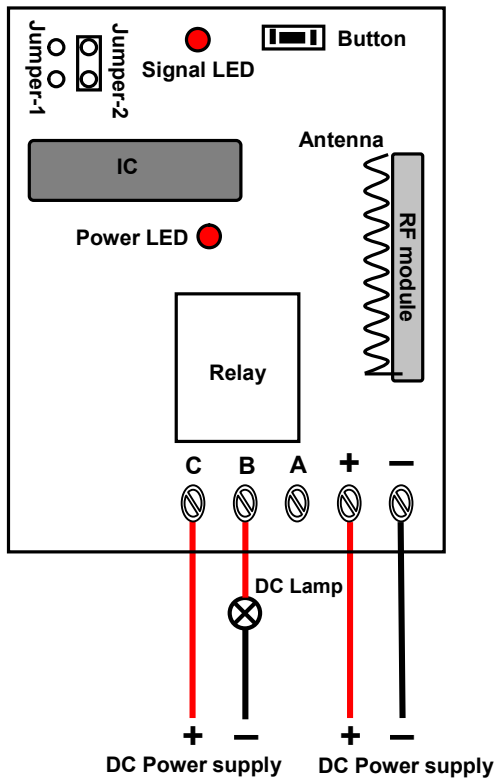

A, B=Normally Closed; B, C=Normally Open.

**Control AC Lamp**

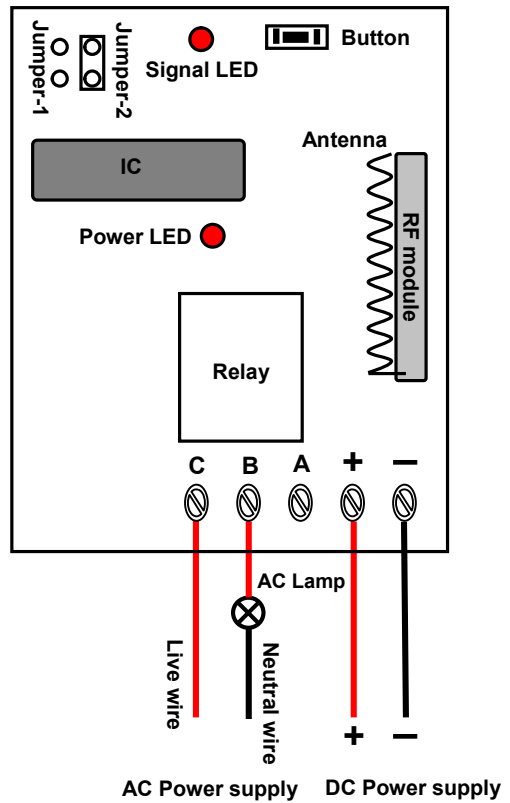

A, B=Normally Closed; B, C=Normally Open.