

RF Wireless Receiver (Model 0020322 S2DA-AC220)

Feature:

Application: It can be used in industry automation, agriculture automation and home automation, such as factory, house, farm, pasture, vehicle, ship, offshore operation, aerial vehicle, field call, etc. It can remote control equipments on land, water and air, such as remote control lights, sirens, locks, motors, fans, windows, blinds, linear actuators, doors, windows, electric solenoid valves, security alarm, business signs and various devices.

Wireless control, easy to install.

Waterproof: The receiver has waterproof case and waterproof connector, it can be installed outdoors.

Universal input: Support voltage of AC110V (100V~120V), widely used in US, Canada... and voltage of AC220V (200V~240V), used in UK, France...

Relay Output: This receiver is relay output, it can be used to operate both DC and AC equipments. The terminal is NO / NC (normally open / normally closed), which serves as a switch. That means you should also connect a separate power supply to it.

With wired control terminals: You can connect sensors, limit switches, manual switches or external devices to control the receiver.

Adjustable delay time: 0 seconds ~ 99 hours

Design with low-power and high-speed CMOS technology.

You can turn on/off the receiver with transmitter (remote control) from any place within a reliable distance.

Wireless RF signal can pass through walls, floors, doors or windows.

With reverse power protection and over current protection.

Reliable control: The receiver only works with the transmitter which use same code.

One/several transmitters can control one/several receivers simultaneously.

You can use two or more units in the same place.

Receiver:

Model No.: S2DA-AC220

Power Supply (Operating Voltage): AC100~240V (110V/120V/220V/240V)

Output: Relay output (Normally open and normally closed)

Working Voltage Range of Relay: AC110~240V or DC0~28V

Transmitting Frequency: 315MHz / 433MHz

Channel: 1 CH

Control Mode: Delay (Press -> ON; Then OFF after the delay time)

Adjustable delay time: 0 seconds ~ 99 hours

Maximum Working Current: 10A / each channel

Static Current: ≤6mA

PCB size: 140mm x 73mm x 18mm

Case size: 192mm x 100mm x 45mm

Work with Fixed code transmitters or Learning code transmitters.

Matching Transmitters:

The receiver can work with different transmitters, such as model C-2 / C-4 (100M), CWB-2 / CWB-4 (50M, waterproof), CP-2 / CP-4/CV-4 (500M), or CB-2 / CB-4 (1000M), CBW-2 / CBW-4 (1000M, waterproof) etc.

Working Range:

With a transmitter (such as C-4) to form a complete set, the working distance can reach 100M in an open ground. The maximum working distance 100M is a theoretical data, it shall be operated in an open ground, no barriers, no any interference. But in the practice, it will be hindered by trees, walls or other constructions, and will be interfered by other wireless signals. Therefore, the actual distance may or may not reach 100M. If you want to have a further working range, you can install an external antenna to the receiver, and you also can use a powerful transmitter, such as CB transmitters.

Usage (with the transmitter C-4):

The receiver can be used to control both DC 0~28V and AC 110~240V equipments.

Notice: The receiver is relay output, not DC/AC power output. Initial state of relay output terminals: Terminals A and B are Normally Open; Terminals A and C are Normally Closed.

If you want to control a DC 12V lamp, do as following:

- 1) Connect the live wire of AC power supply to terminal "L / +", and connect the neutral wire of AC power supply to terminal "N / -".
- 2) Connect terminal C to the positive pole of DC power supply, connect terminal B to the positive pole of DC lamp, and connect the negative pole of DC lamp to the negative pole of DC power supply.

If you want to control an AC 220V lamp, do as following:

- 1) Connect the live wire of AC power supply to terminal "L / +" of INPUT, and connect the neutral wire of AC power supply to terminal "N / -" of INPUT.
- 2) Connect terminal C to the live wire of AC power supply, connect terminal B to one side of AC lamp, and connect another side of AC lamp to the neutral wire of AC power supply.

Press button 1: Turn on relay 1 (connect B and C, disconnect A and B), the lamp 1 is on.

After delay time: Turn off relay 1 by itself (disconnect B and C, connect A and B), the lamp 1 is off.

Press button 3: Turn off relay 1 immediately, no need to wait for delay time.

Press button 2: Turn on relay 2 (connect B and C, disconnect A and B), the lamp 2 is on.

After delay time: Turn off relay 2 by itself (disconnect B and C, connect A and B), the lamp 2 is off.

Press button 4: Turn off relay 2 immediately, no need to wait for delay time.

Press buttons of “+” and “-” on the timer, adjust delay time from 0 second to 99 hours. Two buttons of Timer 1 adjust delay time of relay 1; two buttons of Timer 2 adjust delay time of relay 2. “H” is Hour, “M” is Minute, and “S” is Second. For example, if you set “2 0 M 0 5” on Timer, it means the delay time on Timer 1 is 5 minutes; the delay time on Timer 2 is 20 minutes.

Wired control terminals:

The receiver has manual control terminals, you can connect external devices, sensors, or manual switches to control the receiver.

1) Signal input:

You can connect external devices (with low level output signal) to manual terminals “Signal 1-”, “Signal 1+”, “Signal 2-” and “Signal 2+”, then the external device’s output signal can control the receiver.

When the external device outputs low level signal to manual terminal “Signal 1-” and terminal “Signal 1+”, turns on the relay1(connect B and C, disconnect A and B) , the lamp 1 is on.

When the external device stops to output signal: Turn off relay 1 (disconnect B and C, connect A and B), the lamp 1 is off.

When the external device outputs low level signal to manual terminal “Signal 2-” and terminal “Signal 2+”, turns on the relay 2(connect B and C, disconnect A and B) , the lamp 2 is on.

When the external device stops to output signal: Turn off relay 2 (disconnect B and C, connect A and B), the lamp 2 is off.

2) The manual switches:

You can connect manual switch to terminals “Signal 1-”, “Signal 1+”, “Signal 2-” and “Signal 2+”, and then you can use this manual switch to control the receiver.

When connect terminals “Signal 1-” and “Signal 1+”, turns on the relay 1 (connect B and C, disconnect A and B), the lamp 1 is on.

And when disconnect terminals “Signal 1-” and “Signal 1+”, turns off the relay 1 (disconnect B and C, connect A and B), the lamp 1 is off.

When connect terminals “Signal 2-” and “Signal 2+”, turns on the relay 2 (connect B and C, disconnect A and B), the lamp 2 is on.

And when disconnect terminals “Signal 2-” and “Signal 2+”, turns off the relay 2 (disconnect B and C, connect A and B), the lamp 2 is off.

How to pair the transmitter to the receiver:

- 1) Press the learning button of receiver for 1- 2 seconds; signal LED on the receiver is on. The receiver enters into status of LEARNING.
- 2) Press any one button on transmitter. If signal LED flashes quickly 15 times and turns off, it means learning is successful.
- 3) When receiver is in the status of LEARNING, press again the button of receiver, signal LED turns off, learning process will be discontinued.
- 4) The receiver can learn several remote controls with different codes.

Delete all transmitters:

We have learned remote control to the receiver. If you don’t want the receiver to work with the remote control, you can delete all codes of remote controls, which are stored in the receiver.

Operation: Press and hold the button of receiver until signal LED flashes slowly; release the button, LED keeps slow flash. That means all stored codes have been deleted successfully.

A,B=Normally Closed; B,C=Normally Open

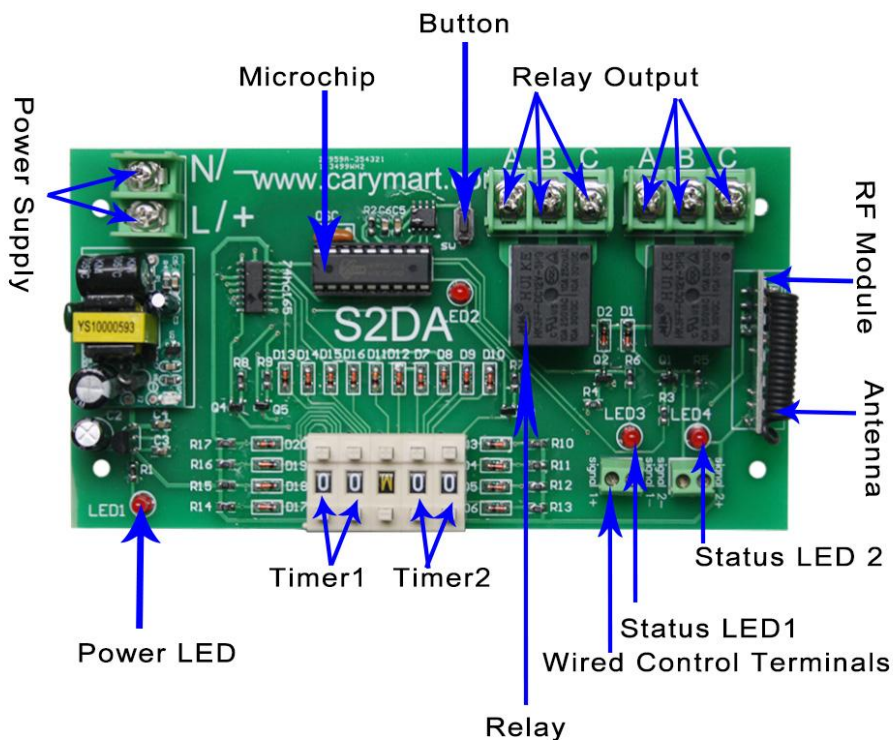

Control AC Lamp

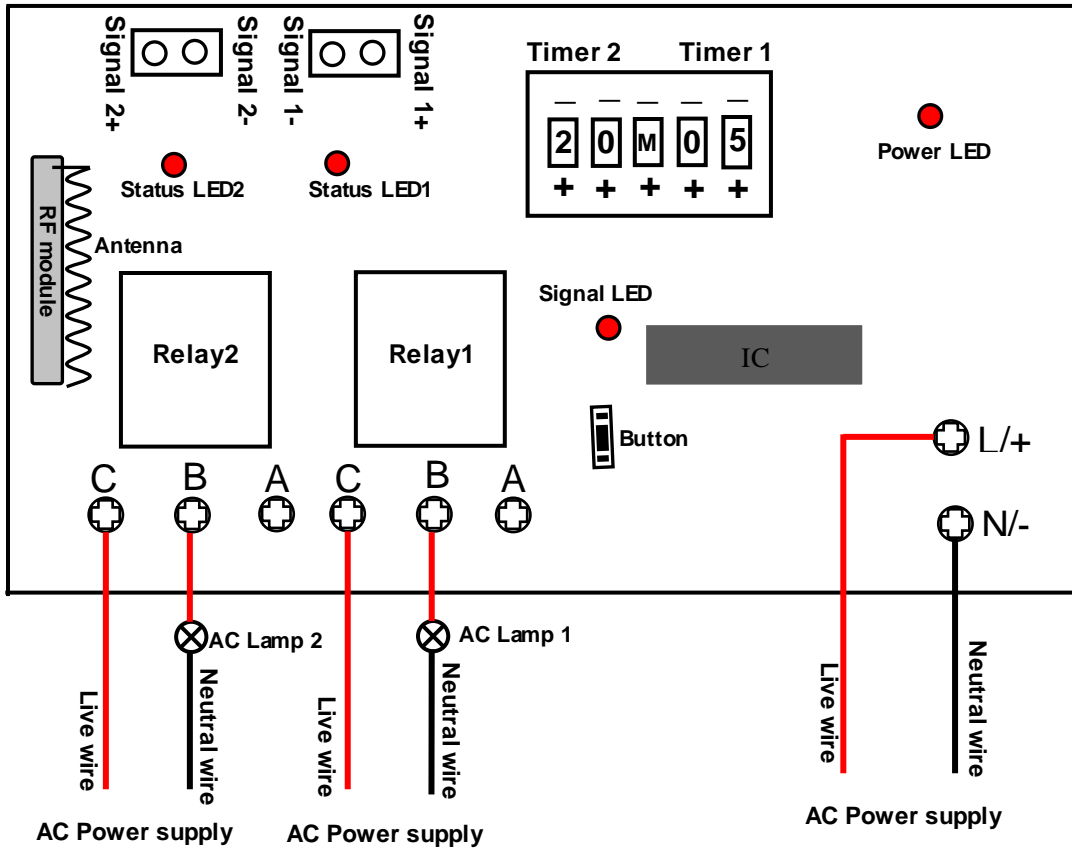

B, C = Normally Open; A, B = Normally Closed

Control DC Lamp

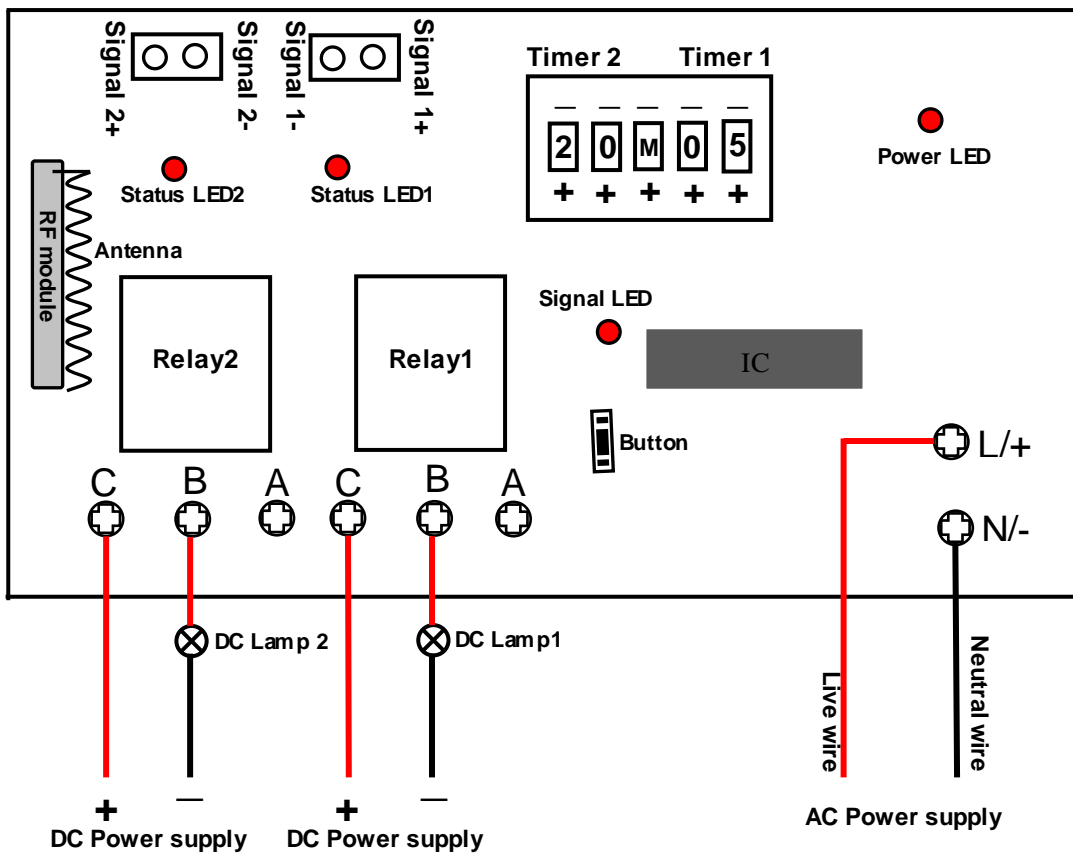

B, C = Normally Open; A, B = Normally Closed