

RF Wireless Receiver (Model 0020063 S2U-DC12)

Feature:

Application: It can be used in industry automation, agriculture automation and home automation, such as factory, house, farm, pasture, vehicle, ship, offshore operation, aerial vehicle, field call, etc. It can remote control equipments on land, water and air, such as remote control lights, sirens, locks, motors, fans, winches, blinds, linear actuators, doors, windows, electric solenoid valves, security alarm, business signs and various devices.

Wireless control, easy to install.

Relay Output: This receiver is relay output, it can be used to operate both DC and AC equipments. The terminals are NO / NC (normally open / normally closed), which serves as a switch. That means you should also connect a separate power supply to equipments.

You can turn on/ off the receiver with transmitter (remote control) from any place within a reliable distance.

Wireless RF signal can pass through walls, floors, doors or windows.

With reverse power protection and over current protection.

Reliable control: The receiver only works with the transmitter which use same code.

One/several transmitters can control one/several receivers simultaneously.

You can use two or more units in the same place.

Receiver Parameters:

Model No.: S2U-DC06 / S2U-DC09 / S2U-DC12 / S2U-DC24

Power Supply (Operating Voltage): DC6V (S2U-DC06), DC12V±1V (S2U-DC12), DC9V±1V (S2U-DC09), DC24V±1V (S2U-DC24)

Output: Relay output (Normally open and normally closed)

Working Voltage Range of Relay: AC110~240V or DC0~28V

Working Frequency: 315MHz / 433MHz

Channel: 2 CH

Control Modes: Toggle, Momentary, Latched, Momentary + Toggle

Static Current: ≤6mA

Maximum Working Current: 10A / each channel

PCB size: 67mm x 50mm x 18mm

Case size: 75mm x 54mm x 27mm

Work with Fixed code transmitters or Learning code transmitters.

Matching Transmitters:

The receiver can work with different transmitters, such as model C-2 / C-3/C-2L (100M), CWB-2 / CWB-3 (50M, waterproof), CP-2/CP-2L (500M), or CB-2 / CB-2L/CB-3 (1000M) etc.

When you set the receiver in toggle or momentary mode, it should work with two buttons transmitter, such as model C-2/C-2L (100M), CWB-2 (50M, waterproof), CP-2/CP-2L (500M), or CB-2/CB-2L (1000M) etc. When you set the receiver in latched mode, it should work with three buttons transmitter, such as model C-3 (100M), CWB-3 (50M, waterproof), or CB-3 (1000M) etc.

Working Range:

With a transmitter (such as C-2) to form a complete set, the maximum working distance can reach 100M in an open ground.

The maximum working distance is a theoretical data, it shall be operated in an open ground, no barriers, no any interference. But in the practice, it will be hindered by trees, walls or other constructions, and will be interfered by other wireless signals. Therefore, the actual distance may not reach this maximum working distance.

If you want to have a further working range, you can install an external antenna to the receiver, and you also can use a powerful transmitter, such as CB series transmitters.

Usage:

The receiver can be used to control both DC 0~28V and AC 110~240V equipments.

Notice: The receiver is relay output, not DC/AC power output. Initial state of relay output terminals: Terminals B and C are Normally Open; Terminals A and B are Normally Closed.

Wiring:

If you want to control a DC 12V lamp, do as following:

- 1) Connect the positive pole of DC power supply to terminal "+", and connect the negative pole of DC power supply to terminal "-".
- 2) Connect terminal C to the positive pole of DC power supply, connect terminal B to the positive pole of DC lamp, and connect the negative pole of DC lamp to the negative pole of DC power supply.

If you want to control an AC 220V lamp, do as following:

- 1) Connect the positive pole of DC power supply to terminal "+", and connect the negative pole of DC power supply to terminal "-".
- 2) Connect terminal C to the live wire of AC power supply, connect terminal B to one side of AC lamp, and connect another side of AC lamp to the neutral wire of AC power supply.

Setting different control modes:

Setting different control modes (We have set the receiver as Toggle control mode before delivery. If you want to use other control modes, do as following operation):

Setting control mode Toggle (with the transmitter C-2): Only connect Jumper-2.

Control mode Toggle: Press -> On; Press again -> Off.

Press button 1: Turn on relay 1 (connect B and C, disconnect A and B), the lamp 1 is on.

Press button 1 again: Turn off relay 1 (disconnect B and C, connect A and B), the lamp 1 is off.

Press button 2: Turn on relay 2 (connect B and C, disconnect A and B), the lamp 2 is on.

Press button 2 again: Turn off relay 2 (disconnect B and C, connect A and B), the lamp 2 is off.

Control DC motor positive reversal direction

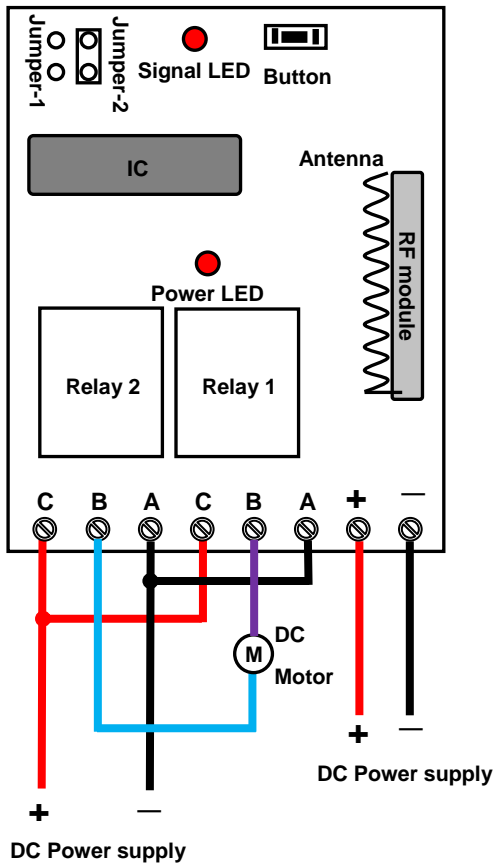

A, B=Normally Closed; B, C=Normally Open.

Control AC motor positive reversal direction

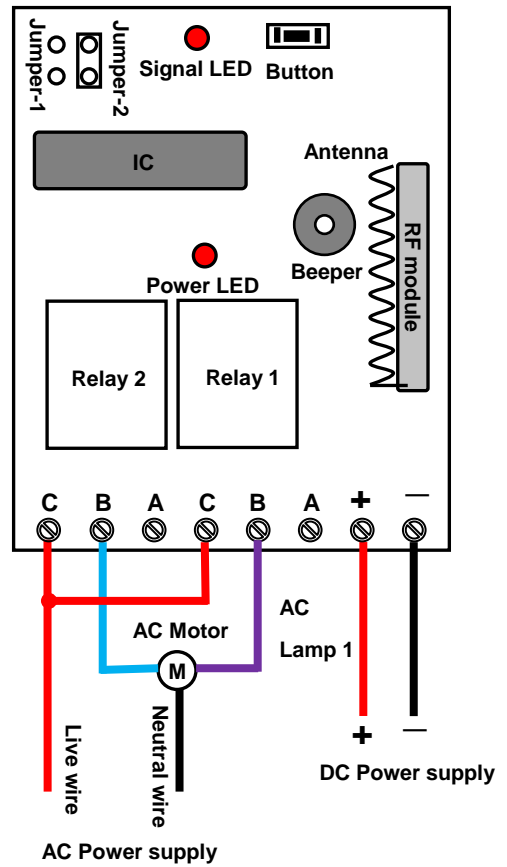

A, B=Normally Closed; B, C=Normally Open.